

REVISION RECORD			
REV	DESCRIPTION	DATE	APPD

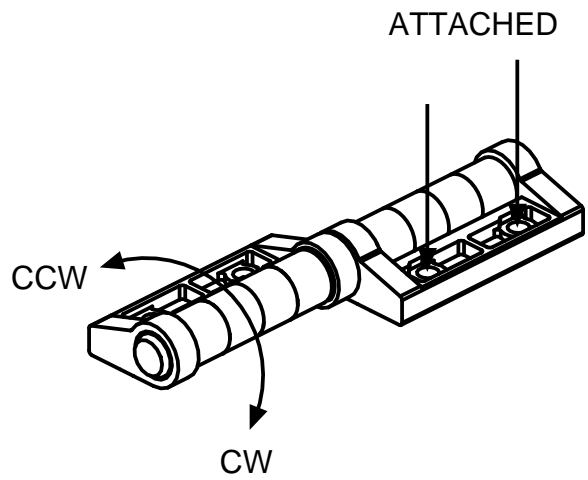

**3001-0020-HNG L**

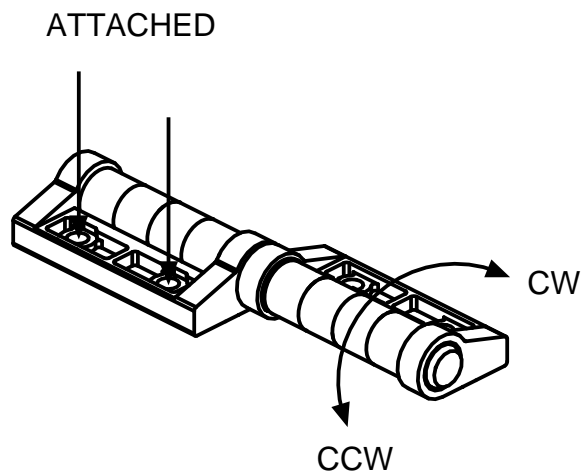

**3001-0020-HNG R**

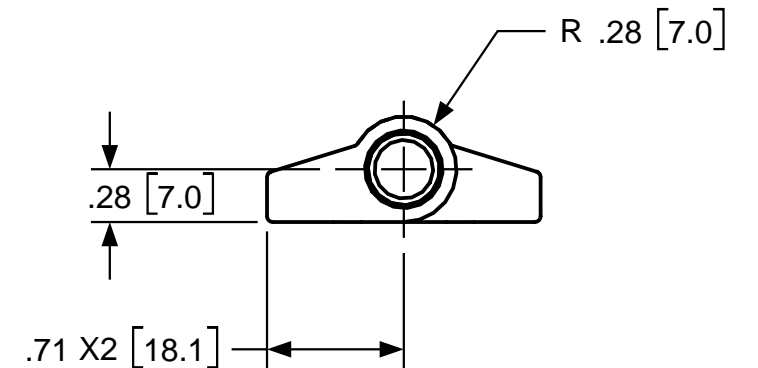
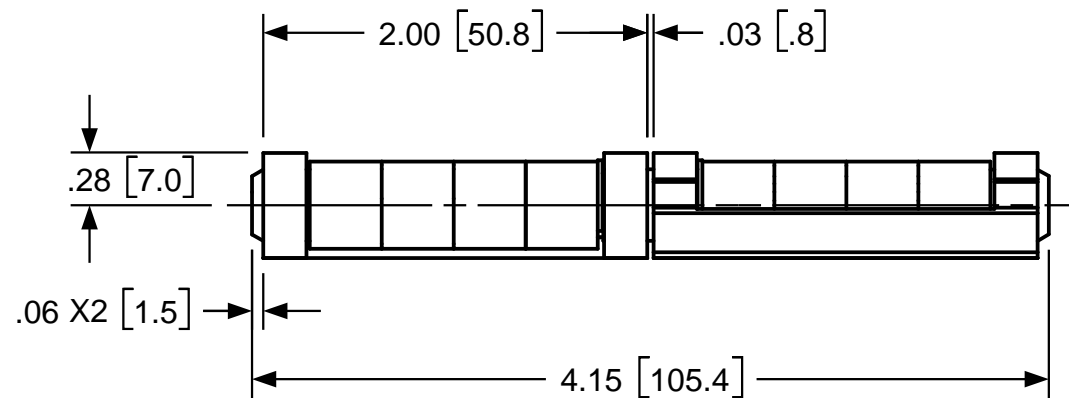
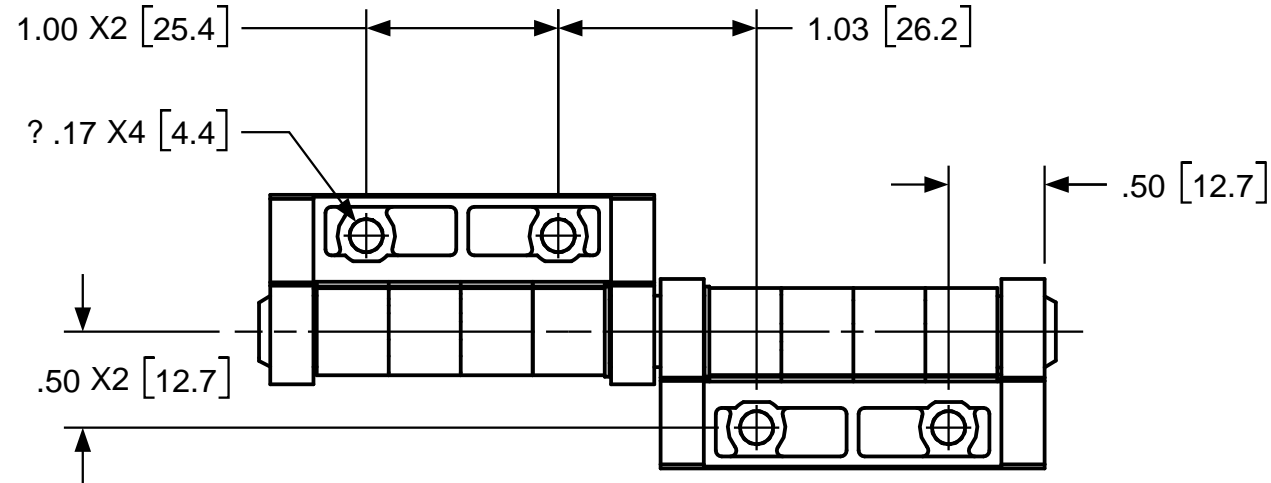

**NOTES:**

- HINGE TORQUE: UNBALANCED.
- 3001-0020-HNG L CCW TORQUE = 40 ± 15% IN.LB.
- 3001-0020-HNG L CW TORQUE = LESS THAN CCW TORQUE.
- 3001-0020-HNG R CW TORQUE = 40 ± 15% IN.LB.
- 3001-0020-HNG R CCW TORQUE = LESS THAN CW TORQUE.
- FINISH: HOUSING AND BANDS TO BE BLACK.**

<b>SHI NELOT</b>		TITLE <b>INTERFACE DRAWING</b>			
ALL INFORMATION ON THIS PRINT ARE PROPRIETARY TO HANAYA, AND SHALL NOT BE USED IN WHOLE OR IN PART WITHOUT HANAYA'S CONSENT.		<b>ENGLISH / METRIC TOLERANCES</b>		MATERIAL <b>ZINC HOUSING STEEL BAND &amp; SHAFT</b>	
		<b>METRIC</b> .X ±.3 MM .XX ±.13 MM .XXX ±.005 MM	<b>ENGLISH</b> .XX ±015 IN .XXX ±005 IN .XXXX ±0002 IN	SIZE <b>B</b>	DWG NO <b>3001-0020-HNG L 40XX 3001-0020-HNG R XX40</b>
USED ON	REV	ANGLE ±1°	DRAWN BY	DATE	SCALE <b>1:1</b>
			SHEET	<b>1</b>	OF <b>1</b>