

REVISION RECORD				
SYM	DESCRIPTION	BY	DATE	APPD

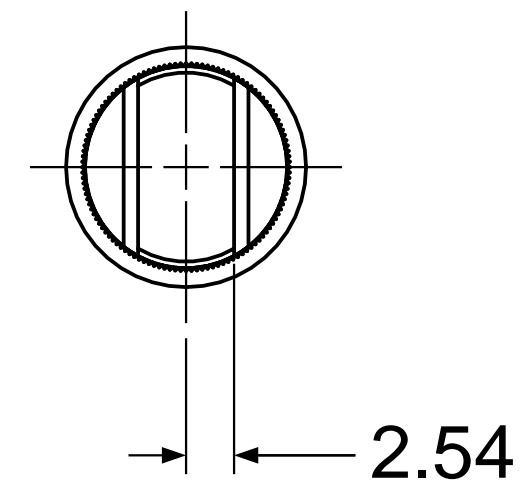
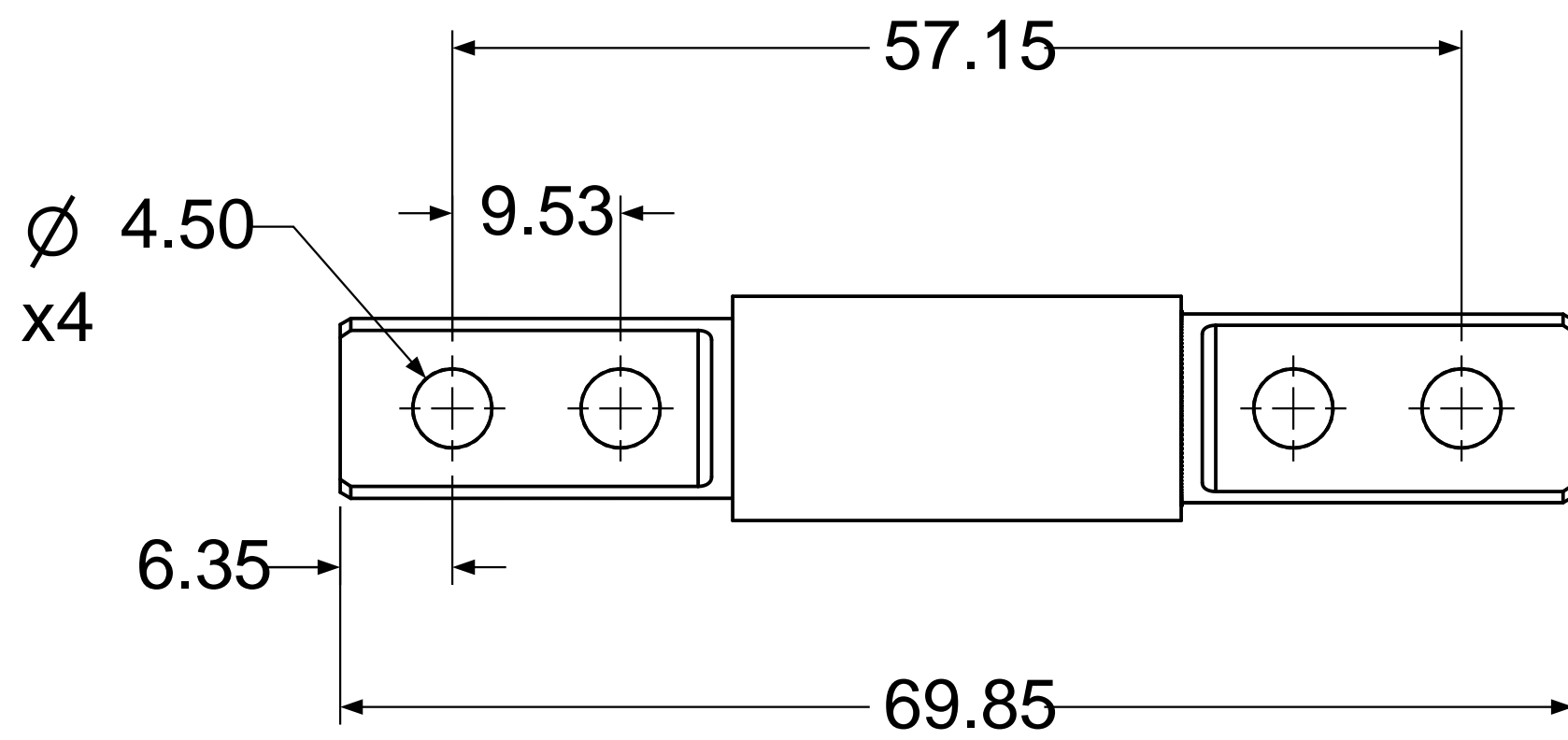
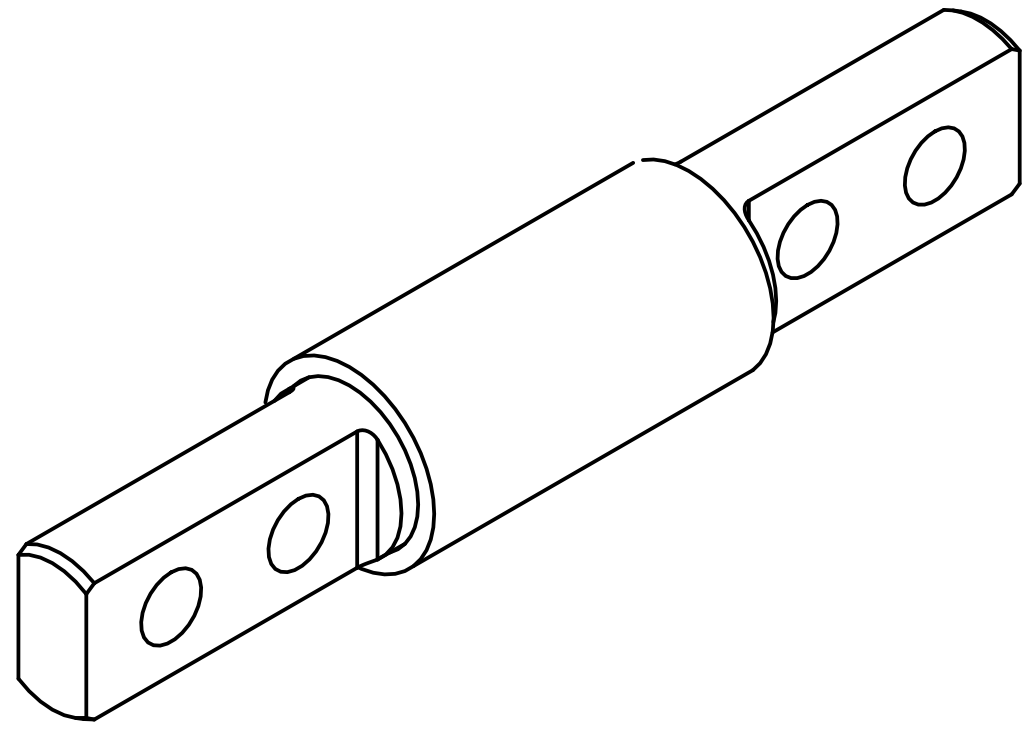

NOTES:

1) CW TORQUE = CCW TORQUE = 3.0 ~ 6.0 IN.LB.

USED ON	SOLID	REV	TOLERANCES		ENGLISH / METRIC		Shinelot Enterprise	
			ENGLISH	METRIC				
NEXT ASSY			.XX ?015 IN .XXX ?005 IN .XXXX ?0002 IN	.X ±.3 MM .XX ±.13 MM .XXX ±.05 MM	DRAWN BY KL	DATE 08/8/4	MATERIAL	
QUANTITY			ANGLES ?.5? SURFACE 63		CHECKED BY	DATE	TITLE 3000-0601-HNG	
PER ASSY, PCS	1						SIZE C	REV 0.0
TOTAL, PCS	1						SCALE 1:1	SHEET 1 OF 1