

REVISION RECORD			
REV	DESCRIPTION	DATE	APPD

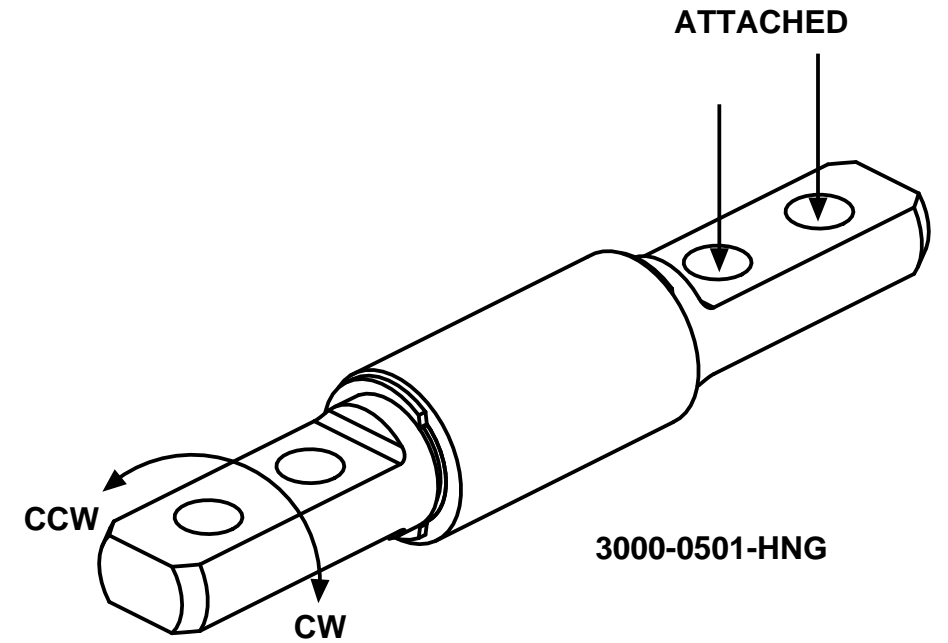
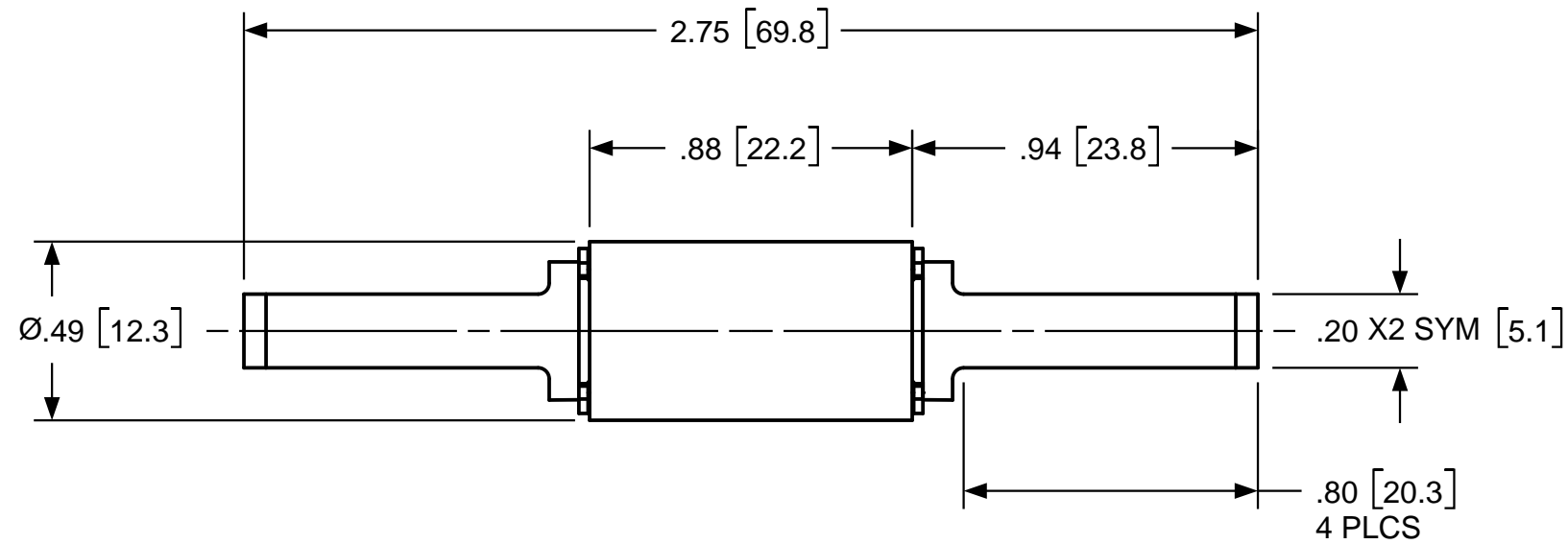
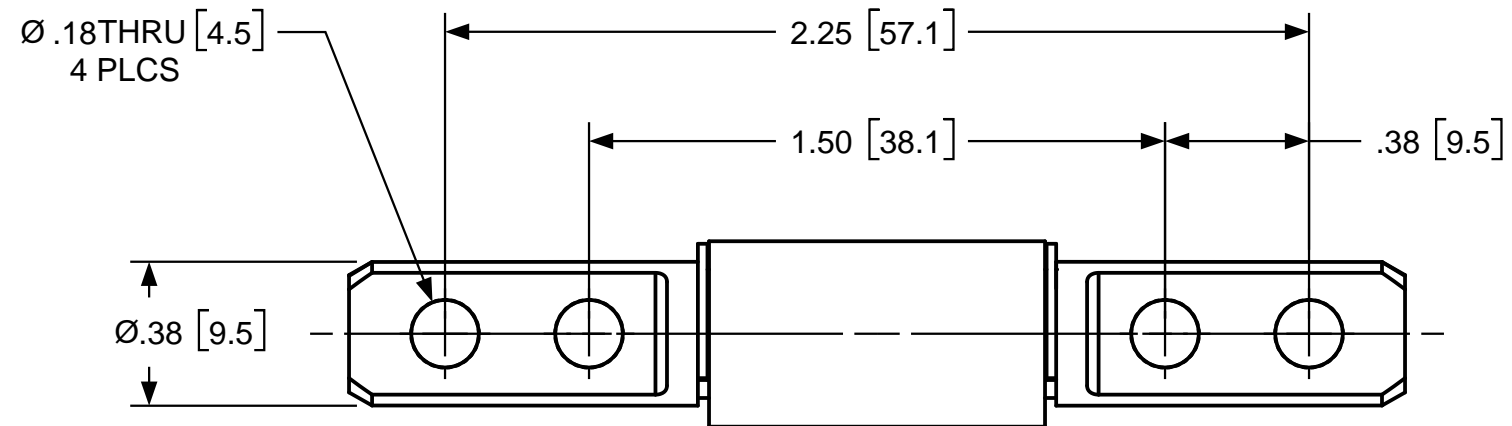

<b>SHI NELOT</b>		TITLE <b>INTERFACE DRAWING</b>			
ALL INFORMATION ON THIS PRINT ARE PROPRIETARY TO HANAYA, AND SHALL NOT BE USED IN WHOLE OR IN PART WITHOUT HANAYA'S CONSENT.		<b>ENGLISH / METRIC TOLERANCES</b>		MATERIAL <b>STEEL BAND &amp; SHAFT</b>	
		<b>METRIC</b> .X ±.3 MM .XX ±.13 MM .XXX ±.005 MM	<b>ENGLISH</b> .XX ±015 IN .XXX ±005 IN .XXXX ±0002 IN	SIZE <b>B</b>	DWG NO <b>3000-0501-HNG</b>
USED ON	REV	ANGLE ±1°		DRAWN BY	DATE
		SCALE <b>2:1</b>	SHEET <b>1</b> OF <b>1</b>		