

REVISION RECORD				
SYM	DESCRIPTION	BY	DATE	APPD

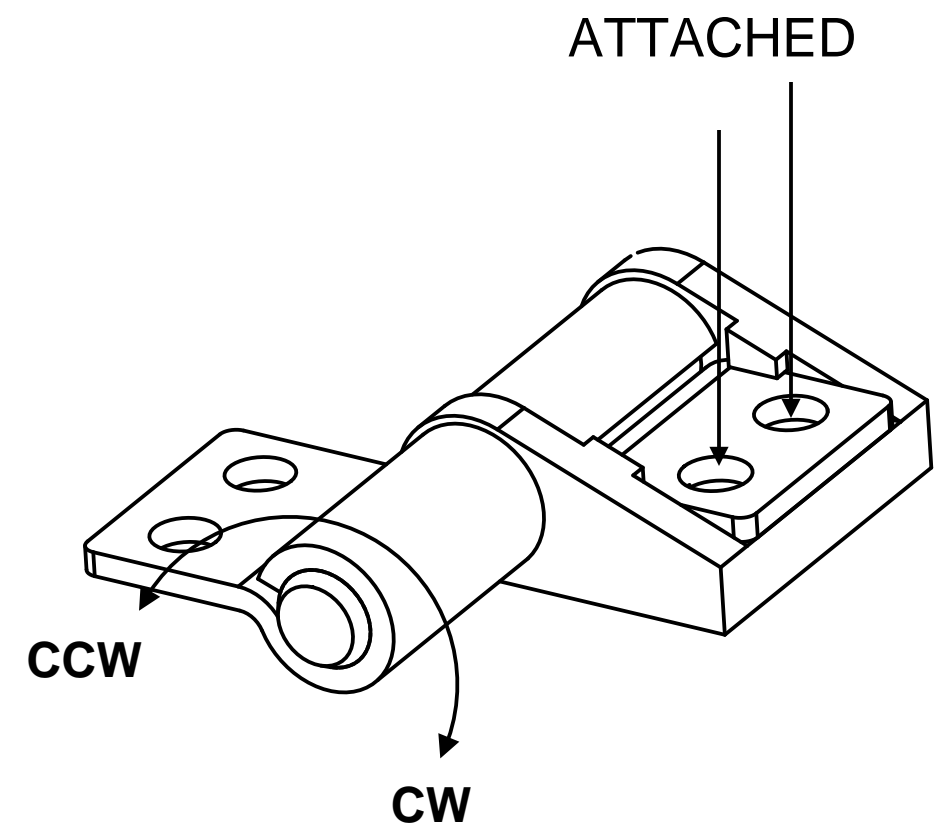

1000-0402-HNG L

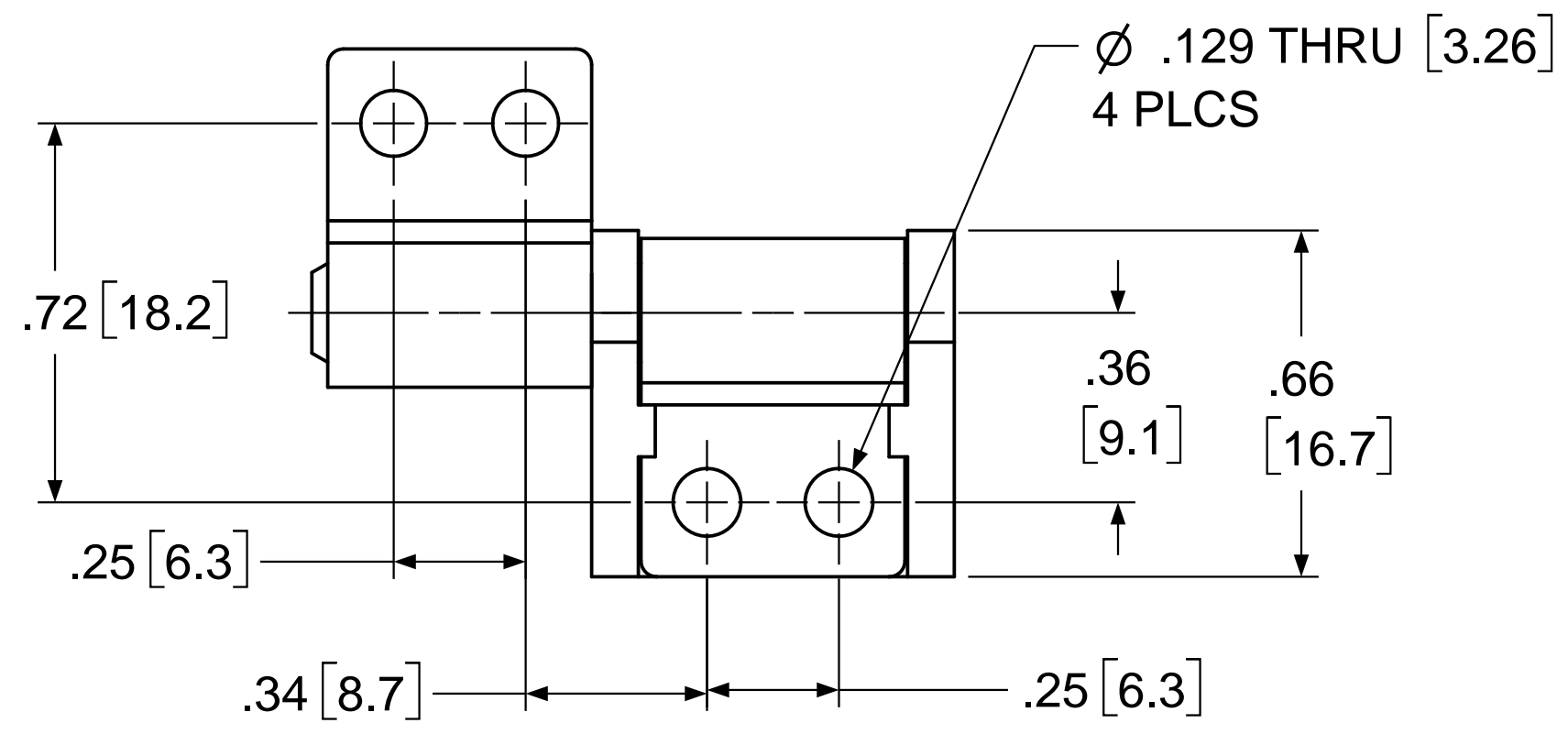
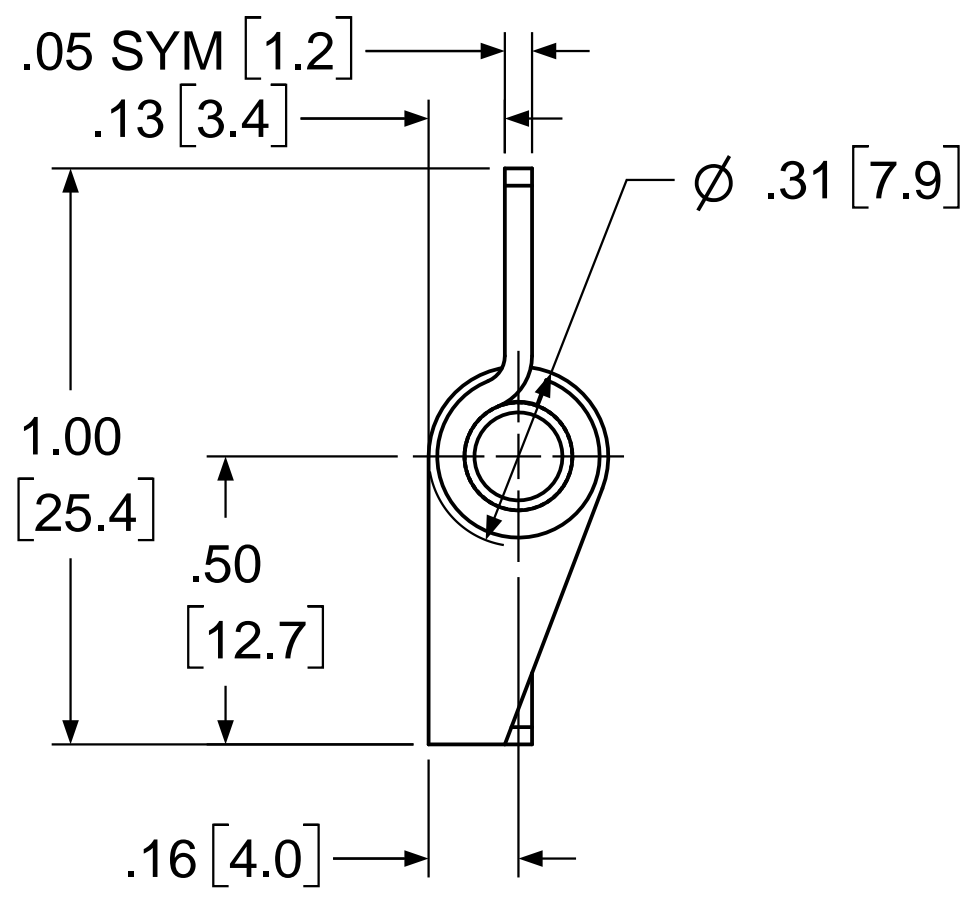
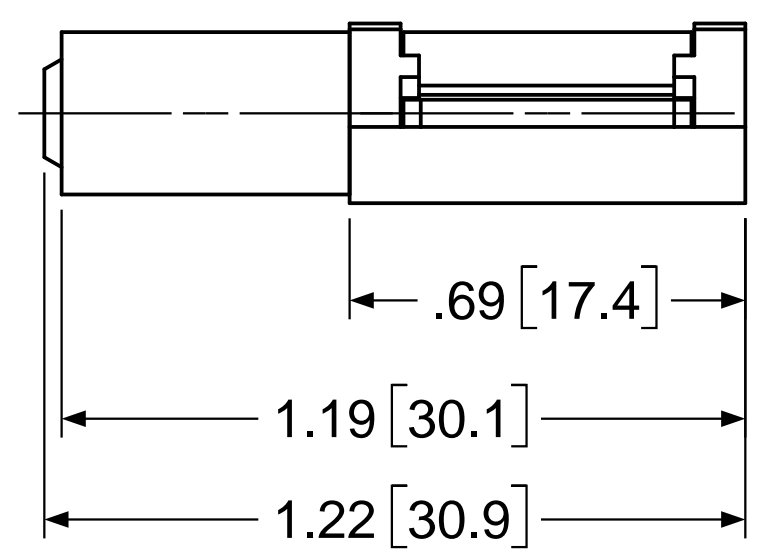

- NOTES:**
- HINGE TORQUE: UNBALANCED.
 - Torque Range:
 Low: 5.0 - 8.0 in.lb
 Med.: 7.0 - 10.0 in.lb
 High: 9.0 -12.0 in.lb

USED ON	SOLID	REV	TOLERANCES		ENGLISH / METRIC		Shinelot Enterprise	
			ENGLISH	METRIC				
NEXT ASSY			.XX ±015 in	.X ±.3 mm	DRAWN BY	DATE	MATERIAL	
QUANTITY			.XXX ±005 in	.XX ±.13 mm	KL	09/2/2	TITLE	
PER ASSY, PCS	1		.XXX ±0002 in	.XXX ±.05 mm	CHECKED BY	DATE	1000-0402-HNG	
TOTAL, PCS	1		ANGLES ±.5°				SIZE	REV
			SURFACE 63				C	0.0
						SCALE	1:1	SHEET 1 OF 1